

[HIRE](#)
[SALES](#)
[SERVICE](#)
[LEASE](#)
[TRANSPORT](#)

## ND SERIES 6.0T FORKLIFT

6.0T DIESEL FORKLIFT



### N SERIES

5.0T - 7.0T

HEAVY DUTY DIESEL FORKLIFTS

UN forklifts are designed to excel in the most challenging environments with increased safety, enhanced cooling systems, reduced noise and vibration all with low maintenance. With refined performance at an affordable price, UN Forklifts reduce the total cost of ownership and provide reliable and efficient solutions to drive productivity in your operations.



MODEL		5.0T	6.0T	7.0T
<b>GENERAL SPECIFICATIONS</b>				
Power Type		Diesel	Diesel	Diesel
Load Capacity	T	5.0T	6.0T	7.0T
Load Capacity	Q(kg)	5000	6000	7000
Load Centre	C(mm)	600	600	600
<b>CHARACTERISTICS &amp; DIMENSION</b>				
Rated Lift Height	H3(mm)	3000	3000	3000
Free Lift Height	H2(mm)	152	152	152
Fork Size (LxWxT)	mm	1220x150x80	1220x150x80	1220x150x85
Mast Tilt Angle (F/R, α/β°)	deg	6°/12°	6°/12°	6°/12°
Fork Overhang (Wheel Center to Fork Face)	X1(mm)	585	585	585
Rear Overhang	X2(mm)	640	640	720
Ground Clearance (Bottom of mast)	H7(mm)	200	200	200
Length to Face of Fork (Without Fork)	L1(mm)	3510	3510	3590
Overall Width	B1(mm)	1998	1995	1998
Mast Lowered Height	H1(mm)	2515	2515	2165
Mast Extended Height (With Backrest)	H4(mm)	4437	4437	4437

[WA](#)
[NT](#)
[QLD](#)
[NSW](#)
[VIC](#)
[SA](#)

[HIRE](#)
[SALES](#)
[SERVICE](#)
[LEASE](#)
[TRANSPORT](#)

## ND SERIES 6.0T FORKLIFT

### 6.0T DIESEL FORKLIFT



MODEL		5.0T	6.0T	7.0T
<b>PERFORMANCE</b>				
Overhead Guard Height	H5(mm)	2445	2445	2445
Turning Radius (Outside)	Wa(mm)	3280	3280	3340
Min.Aisle width for pallets	Asl(mm)	5285	5285	5365
Travel Speed (No Load)	km/h	23/21	23/21	23/21
Lifting Speed (No Load/Full Load)	mm/sec	530/500	530/500	530/490
Lowering Speed (No Load/Full Load)	mm/sec	≥300 / ≤800	≥300 / ≤800	≥300 / ≤800
Max.Drawbar Pull (Full Load)	KN	53	53	52
Max.Gradeability (Full Load)	%	32	27	24
<b>CHASSIS</b>				
Tyre (Front x 4)	mm	8.25-15-14PR	8.25-15-14PR	8.25-15-14PR
Tyre (Rear x 2)	mm	8.25-15-14PR	8.25-15-14PR	8.25-15-14PR
Front Tread	mm	1470	1470	1470
Rear Tread	mm	1700	1700	1700
Wheelbase	Y(mm)	2250	2250	2250
<b>WEIGHT</b>				
Total Weight	kg	7980	8640	9350
Front Axle Weight Distribution (Full Load)	kg	11660	13050	14570
Rear Axle Weight Distribution (Full Load)	kg	1320	1590	1780
Front Axle Distribution (No Load)	kg	4010	3880	3880
Rear Axle Weight Distribution (No Load)	kg	3970	4780	5490
<b>POWER &amp; TRANSMISSION</b>				
Battery	V/Ah	24/90	24/90	24/90
Fuel Tank Capacity	L	120	120	120
Transmission Type		Powershift	Powershift	Powershift
Transmission Stage (FWD,RVS)		2/2	2/2	2/2
Operating Pressure (For Attachments)	Mpa	20	20	20

[WA](#)
[NT](#)
[QLD](#)
[NSW](#)
[VIC](#)
[SA](#)

HIRE

SALES

SERVICE

LEASE

TRANSPORT

## ND SERIES 6.0T FORKLIFT

6.0T DIESEL FORKLIFT



MODEL	5.0T	6.0T	7.0T
<b>EXTRAS INCLUDED</b>			
Side-Shift	•	•	•
Fork positioner	•	•	•
Solid Non-Marking Tyres	•	•	•

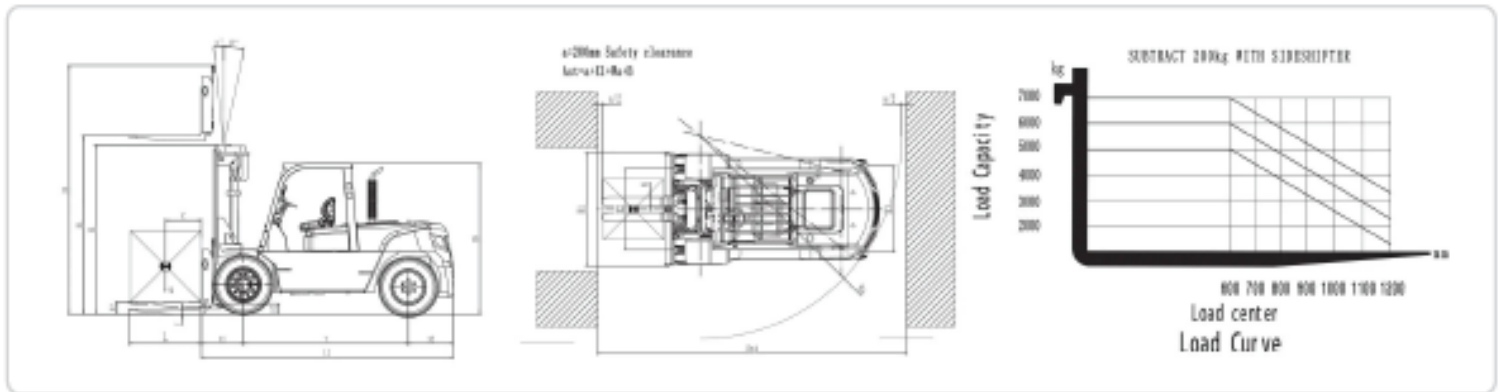

WA

NT

QLD

NSW

VIC

SA